

Free Software Configuration for your Application

INTRODUCTION

TxIsoPack - USB is a fully isolated 4 to 20 mA two-wire loop powered temperature transmitter for in-head assembly.

Complete sensor type selection and range configuration is achieved by connecting the device directly to a PC USB port thus not requiring any other interface, special converter or any additional driver.

The isolated and linearized current output represents the sensor input signal according to the temperature sensor selected.



CONFIGURATION

This product can be supplied pre-configured from factory in large quantities or it can be easily configured by the end user by means of a simple USB cable connected to a regular USB port using the intuitive **NOVUSTxConfig** software.

The Configuration kit comprehends a USB cable and the **TxConfig** software which can be acquired from **NOVUS** or from any **NOVUS** authorized distributor. The **TxConfig** configuration software can be updated free of charge from **NOVUS** website.

Sensor type, operating range, sensor offset and upscale or downscale protection are some of the available parameters which can be configured by using the **TxConfig** software.

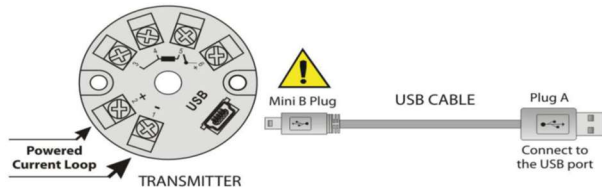

USB Cable Connection

During configuration the transmitter is powered by the USB cable connection thus not requiring any external power supply over the current loop.

SPECIFICATIONS

- INPUT SENSOR: configurable
- Pt100: 2, 3 or 4-wire, 0.170 mA excitation current, Alpha = 0.00385 according to IEC 751 (NBR 13773)
- VOLTAGE: 0 to 50 mVdc. Impedance > 1 MΩ
- TOTAL ACCURACY: maximum error of 0.3 % of maximum range for thermocouples; 0.2 % of maximum range for Pt100 and voltage
- RESPONSE TIME: ≤ 500 ms
- ISOLATION: 1000 Vac for 1 minute between input and output
- OUTPUT: 4-20 mA current or 20-4 mA, two-wire type; linear in respect to the measured temperature
- OUTPUT RESOLUTION: 0.004 mA (12 bits)
- POWER: 12 to 35 Vdc, voltage over the transmitter
- MAXIMUM LOAD in series: $RL = (Vdc - 12) / 0.02 \Omega$ where Vdc is the power voltage
- OPERATING TEMPERATURE: -20 to 75 °C
- RELATIVE HUMIDITY: 0 to 90 % RH
- ELECTROMAGNETIC COMPATIBILITY: EN 50081-2, EN 50082-2
- Internal protection against reversed power voltage polarity
- Internal cold junction compensation for thermocouples
- ABS enclosure, 44 mm diameter and 24 mm maximum height
- Communication cable: mini-B USB cable, 5 pins

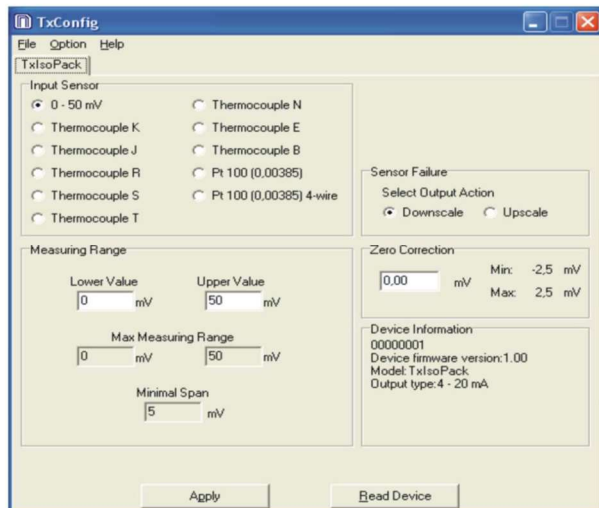

TxConfig Software Main Screen

INPUT TYPES AND MAXIMUM RANGES

SENSOR TYPE	MAXIMUM RANGE	MINIMUM RANGE
T/C type K	-150 to 1370 °C	100 °C
T/C type J	-100 to 760 °C	100 °C
T/C type R	-50 to 1760 °C	400 °C
T/C type S	-50 to 1760 °C	400 °C
T/C type T	-160 to 400 °C	100 °C
T/C type N	-270 to 1300 °C	100 °C
T/C type E	-90 to 720 °C	100 °C
T/C type B	500 to 1820 °C	400 °C
Pt100	-200 to 650 °C	40 °C
Voltage	0 to 50mV	5 mV

Maximum measuring ranges

POB 1778 Greer, SC 29652
414 West Poinsett Street Greer, SC 29650

mike@traskinst.com

www.traskinst.com

Ph: 864-848-3993

Fax: 864-848-9569

TEMPERATURE TRANSMITTER – OPERATING MANUAL V1.1x E

INTRODUCTION

The TxIsoPack is an 4-20 mA 2-wire isolated temperature transmitter, for head assembly. Powered by the current loop, its configuration is accomplished by connecting the transmitter directly to the PC USB interface, not requiring installation of additional drivers.

The output current is linearized and adjusted in function of the input sensor type and range configured.

SPECIFICATIONS

Sensor input: Configurable.

Thermocouples: Types J, K, R, S, T, N, E and B, According to IEC 60584 (ITS-90) Impedance >> 1 MΩ

Pt100: Types: 2, 3 and 4 wires, Excitation 0.17 mA, $\alpha = 0.00385$, According to IEC60751 (ITS-90).

Voltage: 0 to 50 mVdc. Impedance >> 1 MΩ

Sensor Type	Range	Minimum Measurement Range
Thermocouple K	-150 to 1370 °C	100 °C
Thermocouple J	-100 to 760 °C	100 °C
Thermocouple R	-50 to 1760 °C	400 °C
Thermocouple S	-50 to 1760 °C	400 °C
Thermocouple T	-160 to 400 °C	100 °C
Thermocouple N	-270 to 1300 °C	100 °C
Thermocouple E	-90 to 720 °C	100 °C
Thermocouple B	500 to 1820 °C	400 °C
Pt100	-200 to 650 °C	40 °C
Voltage	0 to 50 mV	5 mV

Table 1 – Sensors maximum measurement ranges

Total accuracy: Maximum error 0.3 % of the maximum range for thermocouples, 0.2 % for Pt100 and voltage.

Response time: ≤ 500 ms

Isolation: 1000 Vac for 1 minute between input and output.

Output: 4-20 mA or 20-4 mA current, 2-wired; linear in relation to the temperature measurement by the selected sensor.

Resolution: 0.004 mA (12 bits).

Power supply: 12 to 35 Vdc, voltage across the transmitter.

Maximum load (RL): $RL = (V_{DC} - 12) / 0.02 \Omega$

Were: V_{DC} = Power supply voltage

Operating temperature: -20 to 75 °C

Humidity: 0 to 90 % RH

Electromagnetic compatibility: EN 50081-2, EN 50082-2

Internal protection against the supply voltage polarity inversion.

Cold junction compensation for thermocouples.

ABS box, diameter de 44 mm and max. height 24 mm.

5-pin USB mini-B 5 connection cable.

CONFIGURATION

When the transmitter is already configured with the sensor and desired ranges, no intervention is necessary and its installation may be executed immediately. When it is necessary to change the configuration, it should be made through the TxConfig software.

The transmitter configuration interface (USB cable) can be purchased from the manufacturer or its authorized sales representatives. The setup software may be updated at no charge at the manufacturer's website. To install, execute the file `Tx_setup.exe` and follow the instructions.

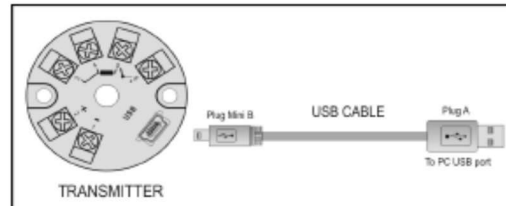

Fig. 1 – USB cable connections

During the setup, the transmitter is powered by the USB, not requiring an external power supply.

The transmitter setup can also be made by connecting it to the loop, using the loop power supply. There is no electrical insulation between the transmitter and the communication port (interface), therefore it is not recommended to configure it with the sensor inlet connected to the process. See Fig. 2.

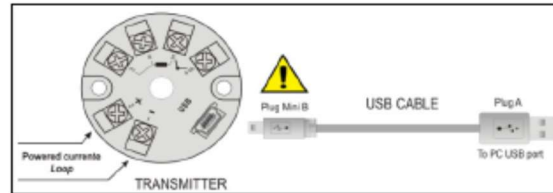

Fig. 2 – USB cable connections – Loop powered

After these connections, the user must run the TxConfig software and, if necessary, consult the *Help* topic to help using the software.

The USB communication port (interface) of the TxIsoPack is not electrically insulated from the transmitter's input.

The TxConfig screen is shown in Fig. 3.



Fig. 3 – TxConfig main screen

The fields in the screen mean:

1. **Input Sensor:** Select the sensor to be used. See Table 1.

2. **Measuring Range:** Define the transmitter measurement range.

Range **Lower Limit:** temperature desired for a 4 mA current.

Range **Upper Limit:** temperature desired for a 20 mA current.

When the **Lower Limit** is set with a value greater than the **Upper Limit** value of the output current operates from 20 to 4 mA (the current decreases as the temperature increases).

Note: The values chosen can not exceed the **Sensor Range** shown in this same field, and also may not establish a range with width (span) smaller than the **Min. Range** indicated later in this same field. See Table 1 of this guideline.

3. **Sensor Failure:** It establishes the output behavior, when the transmitter indicates a failure:

Minimum: output current goes to 3.8 mA (down-scale), typically used for refrigeration.

Maximum: output current goes to 20.5 mA (up-scale), typically used for heating.

4. **Device Information:** This field contains the data identifying the transmitter. This information must be submitted to the manufacturer for any queries.

5. **Zero Correction:** It corrects small deviations presented in the transmitter outlet, for example, when the sensor is replaced.

6. **Send Configuration:** It applies the new setup. Once sent, the setup will be immediately adopted by the transmitter.

7. **Read Configuration:** Reads the current setup in the transmitter connected. The screen now presents the current setup that may be changed by the user.

Note: The factory default configuration is:

- Sensor Pt100, range 0 to 100 °C, 0 °C of zero correction.
- Output at maximum for the sensor failures.

Upon purchase order, the user can define a specific setup.

MECHANICAL INSTALLATION

The TxIsoPack transmitter is suitable to be installed in heads. Vibration, moisture and extreme temperatures, electro-magnetic interference, high voltage and other interferences can permanently damage the unit, and could cause error in the measured value.

DIMENSIONS:

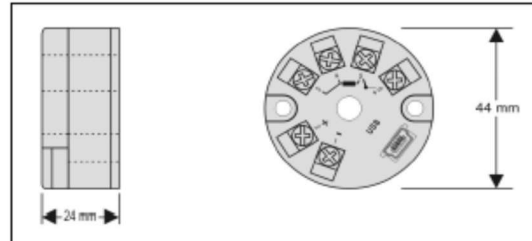

Fig. 4 – Transmitter dimensions

ELECTRICAL INSTALLATION

Polyamide enclosure.

Section of the cable used: 0.14 to 1.5 mm².

Recommended torque in the terminal: 0.8 Nm.

RECOMMENDATIONS FOR INSTALLATION

- Sensor signals conductors must go through the plant system separate from power leads (loop), if possible in grounded conduits.
- The instruments must be powered from the instrumentation power supply circuit.
- In control and monitoring applications is essential to consider what can happen when any part of the system fails.
- It is recommended the use of suppressors in contact coils, solenoids and any inductive load.
- Use compensation cables in the connections using thermocouples.

ELECTRICAL CONNECTIONS

The figures below show the electrical connections required. The terminals 3, 5 and 6 are dedicated to the sensor connection. **LOAD** represents the 4-20 mA current measuring device (indicator, controller, recorder, etc.)

PT100 2-WIRES

Note: When the Pt100 2-wires the terminals 3 and 4 must be interconnected according to the figure below.

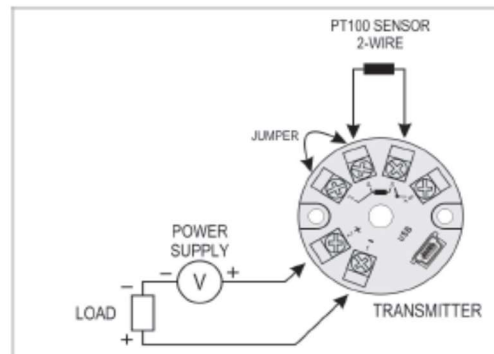

Fig. 5 – Transmitter electrical connections (Pt100 2-wires)

PT100 3-WIRES

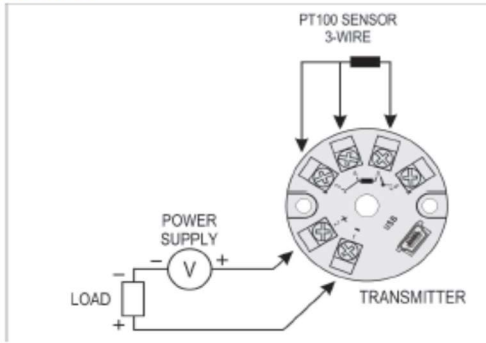

Fig. 6 – Transmitter electrical connections (Pt100 3-wires)

PT100 4-WIRES

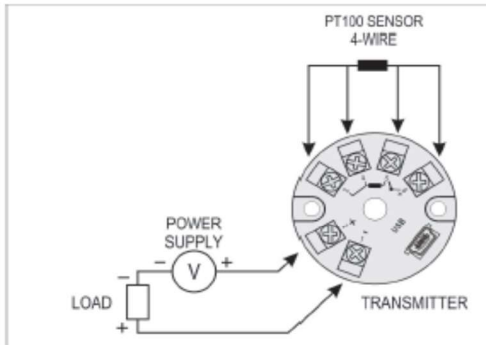

Fig. 7 – Transmitter electrical connections (Pt100 4-wires)

THERMOCOUPLES

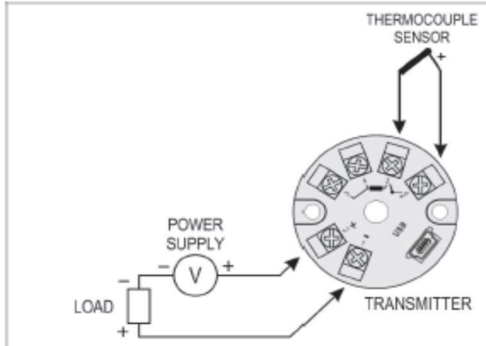

Fig. 8 – Transmitter electrical connections (Thermocouple)

VOLTAGE (0-50 mV)

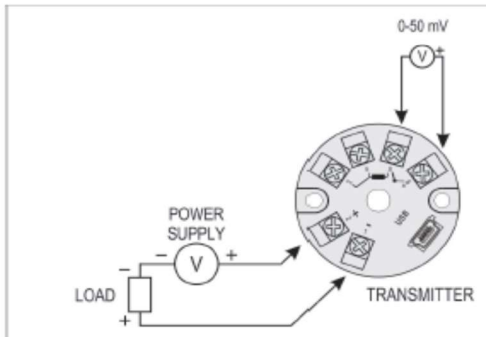

Fig. 9 – Transmitter electrical connections (0-50 mV)

OPERATION

The transmitter is perfectly factory-calibrated with standardized sensors, not requiring any adjustment by the user.

The sensor offset can be also changed through the TxConfig software. The USB connection can be made even with the transmitter connected to the process and operating without causing errors in the measurement. See item **Zero Correction** in the chapter **CONFIGURATION** of this guideline.

The user must choose the most suitable sensor and range to the process. The chosen range must not exceed the maximum range of measurement defined for the sensor and should not be smaller than the minimum range for the same sensor.

It is important to note that the accuracy of the transmitter is always based on the maximum range of the sensor used, even when a mid-range was set. Example:

- The sensor Pt100 has a max. range of -200 to $+650$ °C and total accuracy of 0.2 %, thus we can have an absolute error up to 1.7 °C (0.2 % of 850 °C).
- The absolute error is the same for a wide range as the maximum (-200 to 650 °C), to a narrower band User-defined. (For example: 0 to 100 °C.)

Note: When measurements are made at the transmitter, see if the Pt100 excitation current required by the calibrator is compatible with the Pt100 excitation current used in the transmitter: 0.17 mA.

WARRANTY

Warranty conditions are available on our website www.novusautomation.com/warranty.

POB 1778 Greer, SC 29652
414 West Poinsett Street Greer, SC 29650

mike@traskinst.com
www.traskinst.com

Ph: 864-848-3993

Fax: 864-848-9569